

L120 Main Station L12-H10

Ordering Data

Designation	Type	Item no.
Main Station	L12-H10	128 814 90 AX



- **Main station to be used in connection with IPC**
- **Optical fibre connection with IPC**
- **Compact design**
- **Wide ambient temperature range**
- **Connection via plug-in terminal**
- **Protection type: I M 2 (M 1) EEx ia I**

Application

The main station L12-H10 constitutes a component of the intercom shutdown and interlocking system L 120 of FHF Bergbautechnik GmbH and is designed specifically for the connection to the IPC technology of Bartec.

The main station L12-H10 contains the circuit sections for the specific functions which are required to operate a L120 intercom system featuring shutdown and interlocking functions. Moreover, it contains the switching sections for operating the interfaces of the related programmable controller or control unit.

This includes the termination of the safety circuit, the conditioning of the supply energy of the L120 system line, the monitoring of the intercom connection, the protocol no. (switch position indication) of the stop switches, the generation of the different signal tones and the coupling of the intercom line to an outgoing LF line which leads e.g. to an operator terminal on the surface, or which can be connected with further L120 installations (e.g. of a conveyor road).

The L12-H10 is connected with the IPC through two all-plastic optical fibres. For this connection, the IPC includes a PLC monitor board (1 optical fibre interface / 1 RS422 interface), which is provided with an appropriate operating system. This operating system controls the data exchange with the L12-H10 main station and with all devices of the L120 family that are connected to the L120 system line. At the same time, the PLC monitor board enables the connection of an LCD display to indicate the messages and error states of the L120 system.

If more than one L120 system is to be connected to an IPC, an additional PLC monitor board with 2 optical fibre interfaces and the corresponding number of L12-H10 main stations must be added.

The main station is built in compact design as a 35mm electronics module which can be mounted on DIN top-hat rails and be accommodated e.g. in the intrinsically safe terminal box of the IPC.

The optical fibre coupling between L12-H10 and IPC allows a clear and

simple electric isolation of the different installation components. An intrinsically safe power supply is connected to the L12-H10 and supplies this station and the following devices of the L120 system with power.

In the case of larger installations, an additional power supply can be installed at the end, using an intrinsically safe LIK2 coupler.

The L12-H10 design is very economical in terms of power consumption and only needs ca. 25 mA for its operation.

The connection of type DPM decentralised peripheral modules allows the 8-wire system line not only to be used for the functions "talk", "shutdown" and "protocol no." but also for the transmission of process signals.

The L120 system line consists of pre-fabricated sections that connect the different components of the installation by means of robust plug connectors. The devices can be connected to the line at a random sequence. It must only be ensured that the main station L12-H10 is at the beginning and the end unit L12-E11 at the end of the system line. For safety reasons it is not admissible to branch the line by means of a Tee-joint, as this would be equal to a branch on the safety power circuit.

The main station conforms to category I M 2, protection type EEx ia I, if a supply voltage is applied to its connecting terminals X4 (+12V, 0V), X1, X5.

The power circuits of the main station L12-H10 which remains functional after shutdown of the supply voltage (mainly the LF connection power circuit) conform to category I M 1, protection type EEx ia I.

Performance characteristics

The main station L12-H10 in connection with the operating system of the PLC monitor board executes the following tasks:

- Safety circuit termination through the 19kHz oscillator
- Power supply of the L120 system line through an intrinsically safe 12V power pack, protection type EEX ib I.
- Limitation of the system line power consumption to < 1.1A in the event of a fault
- Conversion of visual into electrical signals in the data circuit TxD /RxD between the PLC monitor board and the L120 system line
- Generation of the following tones: start-up warning tone (either wailing sound or Martinshorn tone adjustable)

- shutdown acknowledging tone
- line interruption tone
- warning during repair work (3 min. max, volume reduction after 12s)
- Disconnection of the LF connection of system line and line cable during acoustic signalling (start-up warning, shutdown acknowledging tone, line interruption tone (start-up warning segment by segment), can be selected / set)
- Reversal of the disconnection when the talk or signal button is actuated.
- Measurement of the L120 system line power consumption and transmission of the value to the PLC monitor board.
- The following messages are detected and transmitted to the PLC monitor board via data message:
 - DC supply voltage below 11V.
 - Safety circuit ready to operate.
 - Enabling of the start-up warning after 5s correct run.
 - Interruption LF power circuit
 - Talk button recognition
- The PLC monitor board accepts the following commands sent via data message:
 - Switch on start-up warning tone
 - Switch on repair work tone
 - Switch on shutdown acknowledging tone

Functioning

The main station L12-H10 basically consists of the circuit components 19kHz oscillator/ termination safety circuit, internal and external power supply, external LF line cable connection, LF (WL) system line circuit connection, central control processor, system line data circuit connection and optical fibre converter.

The safety circuit of the L120 system line is connected to X1, connecting terminals KL1 (SI+), KL2 (SI-). A compound-filled module contains a transmitter with a diode suppressor circuit which decouples the direct current from the safety circuit and launches the 19kHz signal.

The oscillator generates the 19kHz signal by means of an output voltage regulation which ensures that the level of the 19kHz tone, to a large extent, remains independent from the value of the DC supply voltage applied to the terminals SI+ and SI-.

An integrated time-delay circuit ensures that the 19kHz oscillator will only be connected after a delay of approx. 5s in order to avoid transient states after the interruption of the safety circuit.

The LED H2 "Operation" indicates that a DC supply voltage is applied to

the terminals "SI+" and "SI-" of the safety circuit.

The 19kHz oscillator circuit section is electrically isolated from all other circuit sections of the main station.

The 12V supply voltage of the main station L12-H10 (and thus of the L120 system line) is applied to X4 KL1 (+12V) and KL2 (0V).

The LED H1 "Power" indicates the existence of the supply voltage.

By means of a current-limiting circuit, the current flowing into the L120 system line whose supply wires are connected to the terminals X5 KL1, KL2 (DC-) and KL3, KL4 (DC+) is limited to 1.1A. This ensures that a short circuit on the system line does not affect the functioning of the main station.

The internal 5V supply of the main station is generated through an integrated voltage regulator which will also generate the reset signal for the control processor of the L12-H10 if the 5V voltage falls short of a tolerance threshold of 5%.

A fuse and downstream connected resistors limit the power which, in the event of a fault, can be converted in the circuit section of the L12-H10 operated at 5V.

The LED H3 "5V" indicates the existence of the 5V voltage.

At the same time, the regulated 5V supply voltage is used as internal reference voltage. An operational amplifier connected as comparator compares the value of the DC+ voltage with the 5V reference voltage, monitoring it with regard to a value > 11V. If DC+ exceeds the value 11V, this will be indicated by the LED H4 ">11V".

The LF wire pair of the WL system line is connected to the terminals X3 KL1 (WL-) and KL2 (WL+). A circuit consisting of transistors and a voltage divider monitor the LF wire pair for the existence of a direct voltage that is fed in through the end of the system line (end unit L12-E11). Separated by an optocoupler, the signal is transmitted to the processor section for further processing and indicated by LED H5 "WL LTG O.K.".

The shift of the DC potential in the LF wire pair of the main station L12-H10 signals that a talk button on a speaking station of the system line has been pressed. This signal is detected by a comparator circuit and transmitted to the internal circuit section L12-H10 for further processing through an optocoupler.

The voice and tone signals on the LF wire pair are decoupled DC wise and

transmitted to transmitter T1. The secondary side of the transmitter T1 is connected to the internal LF conductor busbar.

A LF line connecting several main stations L12-H10 is connected to the terminals X2 KL1 (b) and KL2 (a). The transmitter T2 electrically isolates this circuit from the internal L12-H10 circuits.

The secondary side of the transmitter T2 also is connected with the internal LF conductor busbar.

The core of the internal circuit of the main station L12-H10 primarily comprises the μ controller of type 80C31, the related program memory, the clock generator, a watchdog and an address decoding circuit.

An A/D converter measures the value of the DC flowing into the system line and converts this value which is then read-in by the μ controller 80C31.

A circuit connected to pin 1 of the μ controller amplifies the audio signals generated by the software of the μ controller (start-up warning tone, faulty line tone, shutdown acknowledging tone), regulates the volume (by means of pot R204) and transmits the signal to the LF (WL) wire pair of the system line by means of an operational amplifier and the transmitter T1.

The circuit section surrounding the relay K1 and switch S1A (selective start-up warning) determine, whether these audio signals will also be audible at the connection X2 (a, b). If "selective start-up warning" (S1A = ON) is set, the setting of the switch S1 = ON on pot R200 will determine at which volume the audio signals will also be heard at connection X2 (a, b).

A peak detector monitors the voltage level of the start-up warning tone for an adequate volume. The signal is also detected by the μ controller 80C31.

After receipt of the corresponding command to switch on the start-up warning, the start-up warning tone runs for a prewarning period of 5s. Then the main station L12-H10 informs the PLC monitor board of the correct run through the signal "enable" and keeps the start-up warning tone running for further a period of 7s.

After receipt of the command "repair work" the start-up warning tone is also emitted during a start-up warning period of 5s. This emission will then be continued for as long as the command "repair work" is valid, although it will not exceed 3min. After a 12s warning period the volume of the tone will be reduced by 1/3.

The audio signals "shutdown acknowledging" and "line faulty" are generated for a period of 20s at intervals of 2 min. for as long as this status has not changed.

The main station L12-H10 has 2 serial communication ports.

One port consists of the optical fibre connection transmitter / TxD (grey connection) and receiver / RxD (blue connection). The receiver re-converts the light-induced pulses transmitted from the IPC PLC monitor board into electrical signals.

Two inverters are used for amplification and, if required, for inversion. A retriggerable timer and the following gates provide a direction control for the data communication which cannot be transmitted in this form via the TxD optical fibres and which ensures that the communication direction is deter-

mined by the start edge of the start bit of a UART frame transmitted by the PLC monitor board to run for a period of 11 bit in the direction from the optical fibre TxD connection to the L120 system line.

Adequate driver modules adapt the TxD signal to the DC+ (12V) level of the L120 system line. The output of the driver module is reversed by the direction control from "enabled" to "TriState", and vice versa.

The first communication participant along a L120 system line for station data transmission (also called protocol no. or switch position indication) is the μ controller of the L12-H10.

After having been recognised and initialised (assigned to address 1) by the PCL monitor board in the initialisation cycle, the controller interconnects a semiconductor switch which connects the driver output with the communication port "Stat. Data" X5, KL 5.

This communication port (the above mentioned second communication port) is bidirectional and also connects a comparator circuit switched as receiving stage which converts the serial data messages transmitted from the other devices on the L120 system line to the internal L12-H10 5V level and transmits them to the optical fibre transmitter (TxD). This will then transmit the signals by means of light-induced pulses to the RxD connector of the PLC monitor board.

Additionally, the main station L12-H10 contains another terminal pair X6 (N.N.) which can be used as supporting terminal for the connection to a profibus DP communication of the IPC via the L120 system line.

Block diagram L12-H10

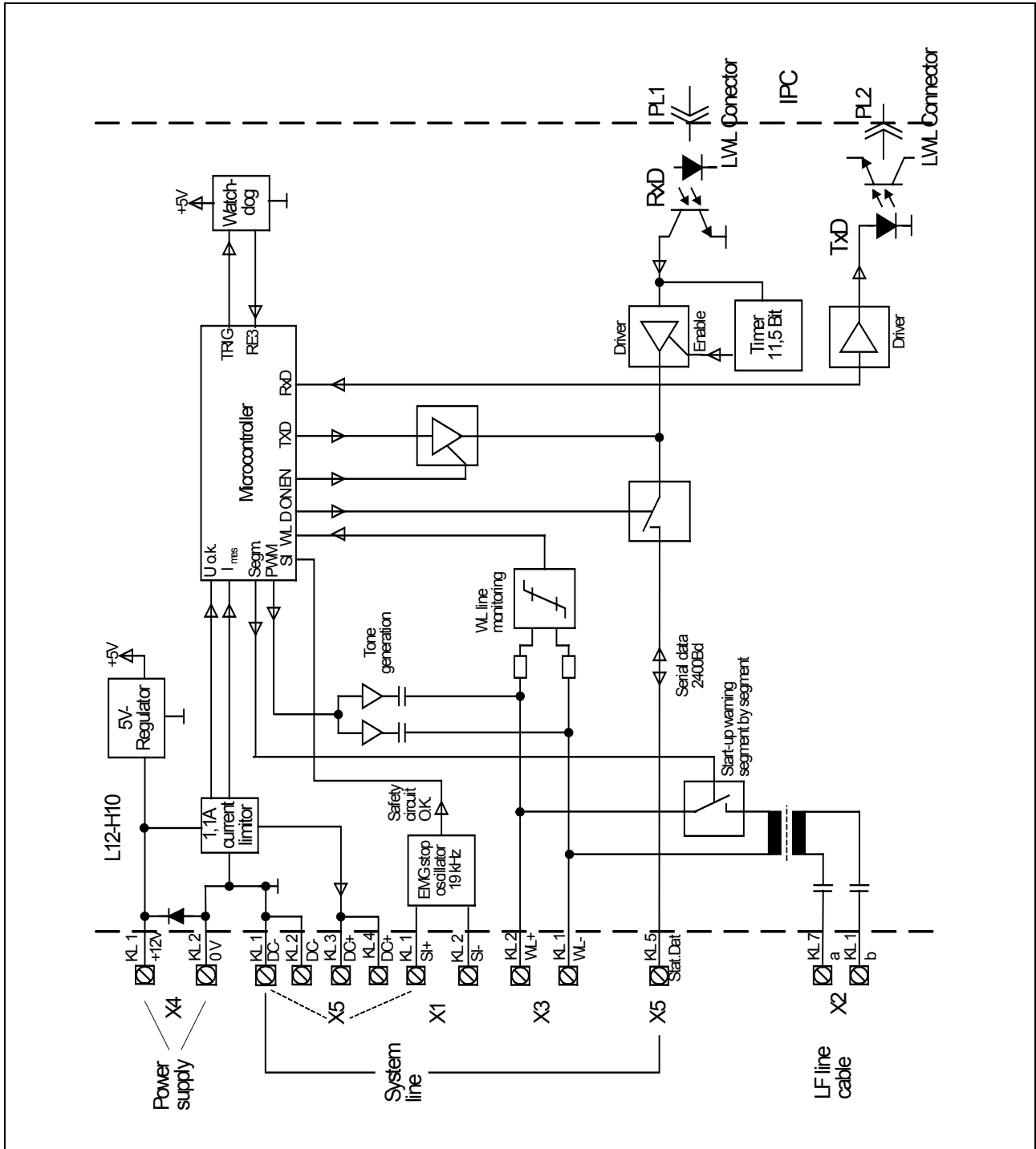

Adjusting elements / Connections

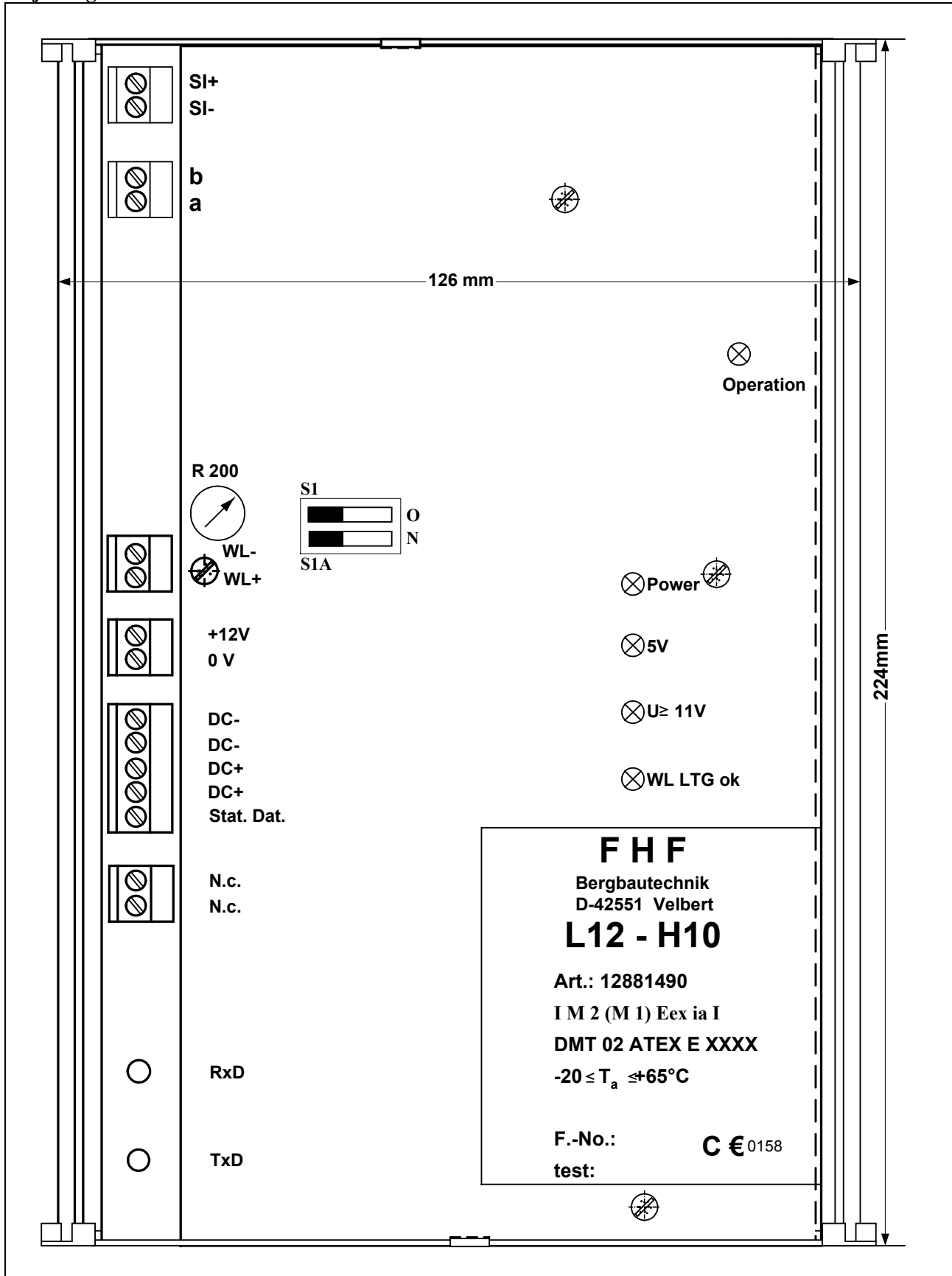

Side view

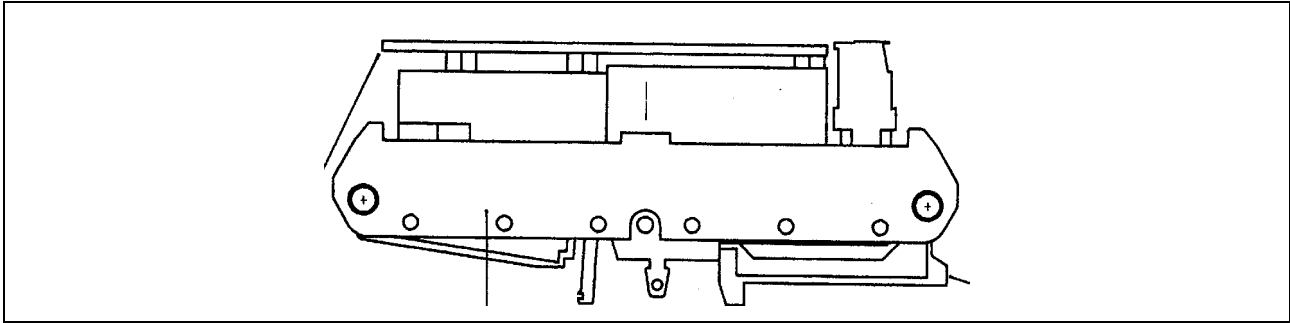

Technical Data L12-H10

Designation Main station

Type L12-H10

Supply**Supply circuit: connecting terminals X4.1(+12V9), X4.2 (0V)**

Voltage U_i 13 V_{DC}
 Amperage I_i 1.3 A
 Effective internal capacitance C_i $\leq 1.2 \mu\text{F}$
 Effective internal self-inductance L_i negligible

Internal supply circuit

Nominal voltage U_n	12 V _{DC}	5 V _{DC}
Max. voltage U_o	13 V _{DC}	6.7 V _{DC}
Nominal amperage I_n	0.2 A	
Effective internal capacitance C_i	$\leq 10 \mu\text{F}$	$\leq 20 \mu\text{F}$
Effective internal self-inductance L_i	negligible	

I/O circuit with galvanic isolation for the connection of intrinsically safe circuits of approved intrinsically safe electrical installations**AF circuit (external WL line) connecting terminal X2.2 (a), X2.1 (b)**

Voltage U_o 800 mV_{AC}
 Amperage I_o 1.1 mA
 Frequency range 0.3 kHz up to 10 kHz
 Internal capacitance C_i $\leq 12 \mu\text{F}$
 Internal inductance L_i $\leq 900 \text{ mH}$
 The AF circuit is safely and galvanically isolated from the other circuits of the main station
 Nominal voltage -6 dB (385 mV at 600 Ω)

Electrical circuits for the connection with the intercom system line**AF circuit, connecting terminals X3.2 (WL1), X3.1 (WL2)**

Voltage U_o	6 V _{DC}	800 mV _{AC}
Amperage I_o	10 mA _{DC}	20 mA _{AC}
Internal capacitance C_i	$\leq 3.6 \mu\text{F}$	
Internal inductance L_i	$\leq 900 \text{ mH}$	
Nominal voltage	-6 dB (385 mV an 600 Ω), 300 Hz up to 10 kHz	

Output circuit (DC+, DC-) connecting terminals X5.1, X5.2 (DC-), X5.3, X5.4 (DC+)

Voltage U_o 13 V_{DC}
 Nominal amperage I_n 0.4 A up to 1.1 A
 Effective internal capacitance C_i $\leq 1.2 \mu\text{F}$
 Effective internal self-inductance L_i negligible

Technical Data L12-H10**Data transmission circuit, connecting terminal X5.5 (Status data / DC-)**

Voltage U_o	13 V _{DC}
Nominal amperage I_n	13 mA
Effective internal capacitance C_i	negligible
Effective internal self-inductance L_i	negligible

Supply circuit for 19kHz Oscillator, (safety circuit)**Connecting terminals X1.1(Si+), X1.2 (Si)**

Voltage U_i	13 V _{DC}
Amperage I_i	250 mA
Power consumption I_n	17 mA
Power P_i	1.5 W
Effective internal capacitance C_i	$\leq 2.5 \mu\text{F}$
Effective internal self-inductance L_i	$\leq 13 \text{ mH}$
AF signal circuit (identical with power supply circuit 19kHz oscillator)	
Voltage U_o	2 V _{AC}
Amperage I_o	16 mA
Frequency	19 kHz

Connecting terminals X6, (potential-free auxiliary terminals for the connection of an intrinsically safe circuit)



Voltage U_i	30 V _{UC}
Amperage I_i	$\leq 1,3 \text{ A}$
Effective internal capacitance C_i	negligible
Effective internal self-inductance L_i	negligible

Optical fibre – interface RXD / TXD (D9 / D5)

Wavelength (sender / receiver)	660 nm
Sender radiant line:	0175 mW/mm ²
Data transmission	2400 Bd (UART Frame: Start-, 8 Data-, Parity (even-, 1 stop-bit)
“Low“ state	DC- (0V)
“High“ state	DC+ (+12V)
Operation mode	continuous operation
Operating position	at choice
Temperature range	
- operation	- 20°C to + 65°C
- storage	- 30°C to + 70°C
- transport	- 30°C to + 70°C
Dimensions	224 x 126 x 58 mm (B x H x T)
Weight	ca. 0.6 kg
Dimensions	224 x 126 x 58 mm (B x H x T)
Weight	ca. 0.6 kg
Test and approval	
- type of protection	I M 2 (M 1) EEx ia I
- approval no.	DMT 03 ATEX E 042 U

Marking

The nameplate is marked as follows:

Company	FHF Bergbautechnik D-42551 Velbert
Type	L12-H10  I M 2 (M 1) EEx ia I DMT 03 ATEX E 042 U  0158 -20 ≤ T _a ≤ +65°C F. No.... test....(initials, month/year)

Configuration

The main station L12-H10 consists of a plastic bottom section which is prepared for top-hat rail mounting and for accommodating one circuit board in its guiding grooves. At its ends, the plastic bottom section is screw-mounted to the plastic side parts, and it is fixed to a 35 mm DIN top-hat rail by means of 2 mounting stands. The circuit board is inserted into the bottom section and locked in position through the side parts.

The circuit board carries all the electronic components and the connecting terminals designed as plug-in terminals. The connecting terminals are grouped and feature the required clearance and leakage paths towards adjacent circuits.

The circuit board is covered by a cover plate which is made of transparent plastic and mounted on spacers. The plate carries the marking for the connecting terminals, the LEDs as well as the data to be identified .

The 8 connecting wires of a L120 system socket-contact are to be connected to the plug-in terminals of the L12-H10. This socket-contact is to be bolted to the wall of the enclosure housing the main station.

Assembly & Commissioning

The main station type L12-H10 is to be installed in a housing ensuring at least a protection of type IP 54 as per EN 60529.

The internal wiring (inside this housing) must be executed in accordance with section 6.4.11 and 7.6.e of EN 50020:1994.

Connecting terminals or plug connectors for intrinsically safe circuits must be arranged as per section 6.3.1 and 6.3.2 of EN 50020:1994.

The interconnection with other devices must be certified separately.

Prior to commissioning, the fixing of the module, the installation and their connection technique is to be verified.

Maintenance

The main station L12-H10 and its components are maintenance-free.

Safety Advice

In the event of an explosive atmosphere (increased methane content) the user will be responsible for the power supply circuit connected to the terminals X4 (and thus also to X1, X3, and X5) to be shut down and thus the DC connections to be de-energized.

The circuit certified in connection with an intrinsically safe installation in the main station L12-H10 that remains functional, basically the through-connection of the LF power circuit between X2 and X3, will then conform to category I M 1, protection type EEx ia I.

Warning and Safety Advice

The apparatus is a flameproof device designed for the operation within explosive atmospheres. It complies with safety class group I M 2 (M 1) and is appropriate for the operation underground.

In the event of an explosive atmosphere (increased methane content), the user will be responsible for the power circuit connected to the terminals X4 (and thus to X1, X3 and X5) to be shut down and for the DC+ and DC- connections to be de-energized. The circuit still kept operable in connection with an approved intrinsically safe installation within the main station L12-H10, this mainly concerns the through connection of the LF circuit between X2 and X3 corresponds to category I M 1, protection type EEx ia I.

Please pay particular attention to the following warning and safety advice:

The apparatus is to be connected and installed in accordance with the specified installation instructions by qualified personnel, taking into account the protection type indicated.

The interconnection with other electric equipment must be separately certified.

The device may only be connected and operated with the specified voltage. The polarity specifications are to be observed.

Replace faulty components only by the appropriate genuine spare parts.

Make sure the housing is not damaged. Do not operate faulty devices, shut them off immediately.

If the device is operated in an industrial installation, the rules for the prevention of accidents for electrical installations and equipment of the association of the industrial employer's social insurance against occupational accidents shall be observed.

The device may only be operated under the specified ambient conditions. Unfavourable ambient conditions may damage the appliance, possibly jeopardising the user's life as a result. Unfavourable ambient conditions may be:

- moisture, dust (observe type of protection)
- air humidity too high (> 75% rel., condensing)
- inflammable gases, vapours, solvents not covered by the protection class of the device.
- ambient temperatures too high (>+40°C)
- ambient temperatures too low (<-20°C).

The ambient temperature specified for the device may not be exceeded or failed to be reached during operation, storage and transport.

The extension and the installation of further parts is not permitted.

Repair work may only be realised by the manufacturer or by a person authorized by the manufacturer. Subsequently, a new routine test for the device must be carried out.

Make sure the device is protected against damage during transport, storage and when not in use. Disconnect the battery to prevent its premature discharge.

Attention:

Disregarding the above points will nullify the explosion protection. The device then represents a danger to the life of the operator and may cause a hazardous atmosphere to explode.